

APPENDIX 3 / ANEXO 3

**SPORTING REGULATION
REGLAMENTO DEPORTIVO**

Timing Transponder

Each team must equip their vehicle with a MyLaps transponder. The timing transponder must be mounted in the front right wheel arch behind the front axle as shown underneath. The illustration below refers to all vehicles. Consult the Series Technical Manager or Scrutineer if needed.

If you have driver-ID system from Mylaps installed please communicate it and the driver order to timekeeping.

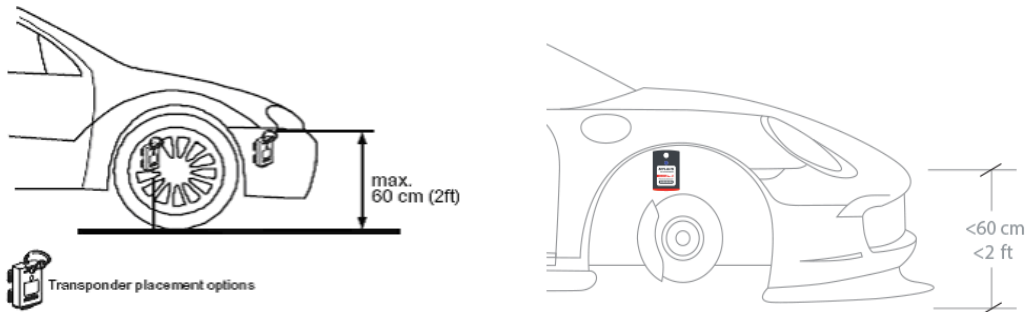

Transponder placement options

TRANSPONDER INSTALLATION AREA

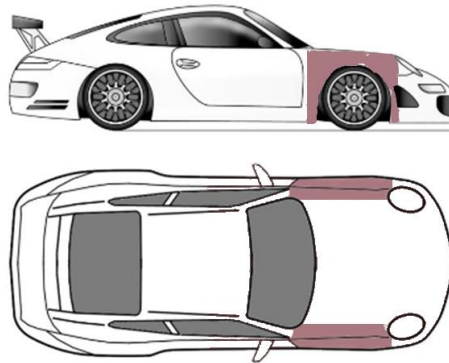

The mounting position of the transponder of a rechargeable or direct powered transponder is the same. The position must be identical on all cars competing in the championship. Fix the transponder vertically, at a maximum of 60cm (2ft) above the track. Make sure that the transponder has a clear view to the track with no metal or carbon fibre underneath. Maximum operating temperature should not exceed 122F/50°C.

Please always remember that **metal** and/or **carbon** will shield the signal of the transponder against being detected by a loop. Carbon will do that even more so than metal. Also, bundles of electric cables will disturb the signal in such a manner that the loop cannot receive the signal.

For the GT Sport series, as well as for the support races that share the event, it will be necessary to have a transponder brand MYLAPS (former AMB) in operation.

Compatible Transponders



The Organising Committee
El Comité Organizador

El presente ANEXO queda aprobado a efectos deportivos por indicación de la FIA.

Madrid, **08-03-2023**

[Signature]

Fdo.: Paloma Izquierdo
Directora Deportiva

Madrid, Marzo/March 2023